

AL600/AL690 HYBRID VEHICLE LIFTS



INSTALLATION & SERVICE MANUAL



TABLE OF CONTENTS

- SAFETY 4**
 - Safety Definition 4
- INTRODUCTION 5**
 - Device Name: Harmar Hybrid Vehicle Lifts 5
 - Read and Understand 5
 - Technical Specifications 5
- PREPARATION 6**
 - Required Tools 6
 - Unpacking the Lift 6
 - Packing List 7
 - Installation Procedure Overview 8
 - Single Person Installation Option 8
- INSTALLATION 10**
 - Wiring the Vehicle 10
 - AL600 Installation 12
 - AL600 Installation with Removable 3rd Row 12
 - AL600 Installation with Folding 3rd Row 16
 - AL690 Installation 20
 - AL690 Installing the Front Leg 20
 - AL690 Installing the Rear Leg 21
 - Chair/Scooter Preparation 25
 - Anchor Plate Installation 25
 - Anchor U-Bolts 26
- TROUBLESHOOTING 27**
 - Manual Override 28
- MAINTENANCE & INSPECTION 30**
 - Dealer Maintenance Schedule 30
 - Preferred Cleaning and Lubrication Maintenance 30



SAFETY

SECTION 1

SAFETY

SAFETY DEFINITIONS



This safety alert symbol appears when the lift detects an issue within the unit that may affect the user's safety. Please follow the message that accompanies this safety alert symbol.

If you do not understand any portion of the installation procedures, please consult Harmar's Technical Service Department at 800-833-0478. Do not attempt to install or use this lift if you have any hesitation or question. Serious injury or damage can result if proper procedures are not followed.

WARNING

Indicates a hazardous situation that could result in death or serious injury.

CAUTION

Indicates a hazardous situation that could result in minor or moderate injury.

NOTICE

Indicates a situation which can cause damage to the lift and/or the environment, or cause the lift to operate improperly.

NOTE: Indicates a condition that should be followed in order for the lift to function in the manner intended.

SECTION 2

INTRODUCTION**DEVICE NAME:
AL600 / AL690 HYBRID
VEHICLE LIFTS**

Indications of Use: The Harmar Hybrid Vehicle Lift is intended to lift, secure and transport an unoccupied mobility device for patients of mobility-impaired persons.

READ AND UNDERSTAND

This manual provides the proper installation and service of the Harmar Hybrid Vehicle Lifts. Please refer to this installation manual for install instructions. Any alterations to the equipment without written authorization by the manufacturer is prohibited and will void the warranty.

**TECHNICAL
SPECIFICATIONS**

Visit harmar.com for specifications on the specific lift model and configuration.

PREPARATION

SECTION 3

PREPARATION

Installations may vary to some degree, but below are the basic tools to have on hand for a Hybrid Lift installation.

If you have any questions, concerns or comments, please contact our Technical Service Department at 800-833-0478 or tech@harmar.com.

REQUIRED TOOLS

- Socket Set:
 - $\frac{9}{16}$ "
 - $\frac{7}{16}$ "
 - $\frac{3}{4}$ "
 - $\frac{3}{8}$ "
- Wrench Set:
 - $\frac{9}{16}$ "
 - $\frac{7}{16}$ "
 - $\frac{3}{4}$ "
- Allen Wrench Set:
 - $\frac{1}{8}$ "
 - $\frac{3}{16}$ "
 - $\frac{5}{16}$ "
- Wire Cutters
- Needle Nose Pliers
- No. 2 Flat Head Screwdriver
- No. 2 Phillips Head Screwdriver
- Marking Implement
- Tape Measure

UNPACKING THE LIFT

1. Check the box contents. Review each part against the packaging list to ensure that all parts have been included. If any parts are missing or damaged, contact Harmar immediately.

 **WARNING**

Do not attempt to install a lift that has missing or damaged parts.

 **WARNING**

Never attempt to pick up the lift from the box, ground or on/off a vehicle alone. Two people should work together to place this lift inside a vehicle. If only one person is available, please follow the short disassembly procedure on next page.

RECOMMENDED TORQUE TABLE

THREAD DIAMETER	TORQUE (FT-LB)		WRENCH SIZE
	Nylon Lock Nut	Hex Nut	
$\frac{1}{4}$	8	10	$\frac{7}{16}$
$\frac{5}{16}$	17	19	$\frac{1}{2}$
$\frac{3}{8}$	30	35	$\frac{9}{16}$
$\frac{1}{2}$	69	85	$\frac{3}{4}$
$\frac{5}{8}$	135	170	$1\frac{5}{16}$

PACKING LIST

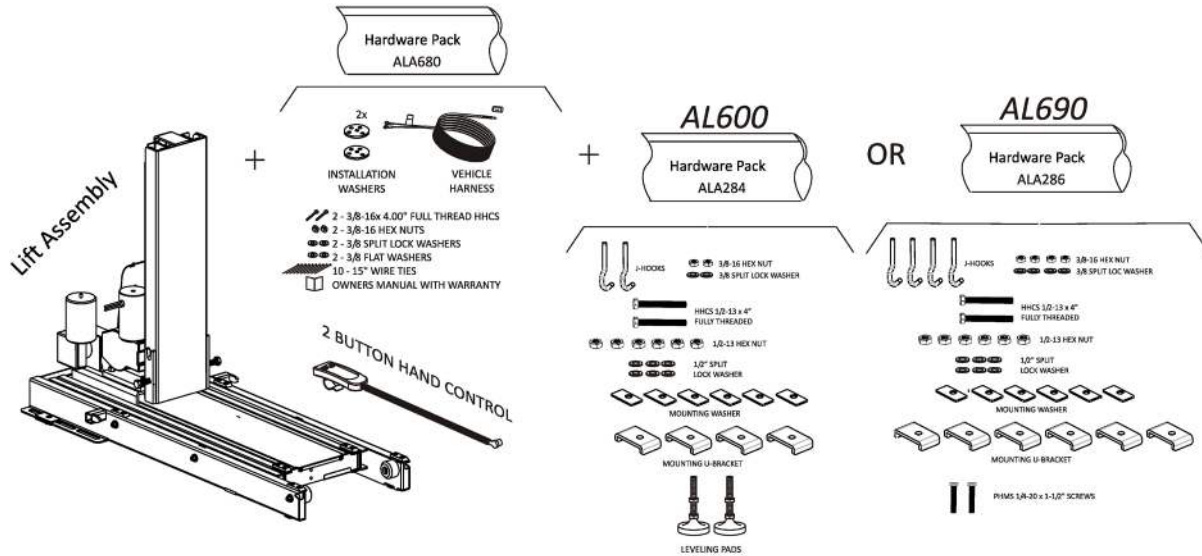

AL600

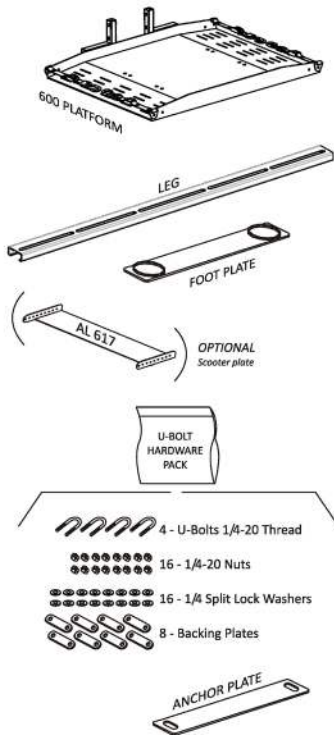

AL690

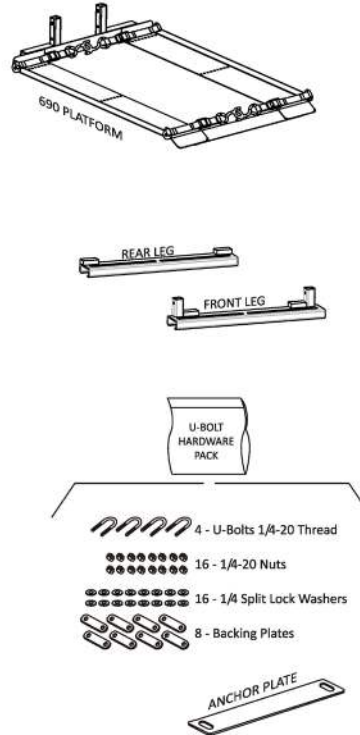

INSTALLATION PROCEDURE OVERVIEW

1. Install Wiring Harness. Installing the wiring harness first will ensure you have power to the lift during installation. This allows access to platform assembly outside the vehicle and at waist level. **See page 15.**

NOTE: If you skip this step, use a 12V shop battery.

2. Remove Seating and Determine Lift Placement. For AL600 (**See page 12**) this is usually the third row; for AL690, (**See Page 20**), second row. Determine mounting range by climbing inside cargo area and closing access door. Measure from inside the door threshold to determine the lift's fully-stowed placement. For the AL600, measure to 43"; for AL690, measure to 55".

See Figure 3-1

Look at the floor in the mounting area. If seat removal reveals seat attachment points, or "dog bones," you will not need to drill.

If no attachment points exist in the area, you will need to drill two $\frac{3}{8}$ " holes approximately 1" to 10" from your measurement point.

(See installation section for details.)

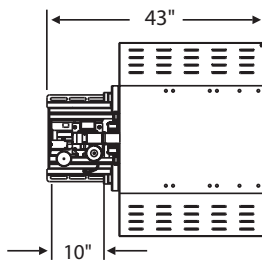

Figure 3-1

SINGLE PERSON INSTALLATION OPTION

We recommend two people install the lift together. If only one person is available, a few extra steps make the lift lighter and more manageable to permit installation.

WARNING

Never attempt to pick up the lift from the box, ground or on/off a vehicle alone. Two people should work together to place this lift inside a vehicle.

If only one person is available, please follow the below disassembly procedure.

1. Remove connections at limit switch and remove power connections at 4-way plug. **See Figure 3-2**

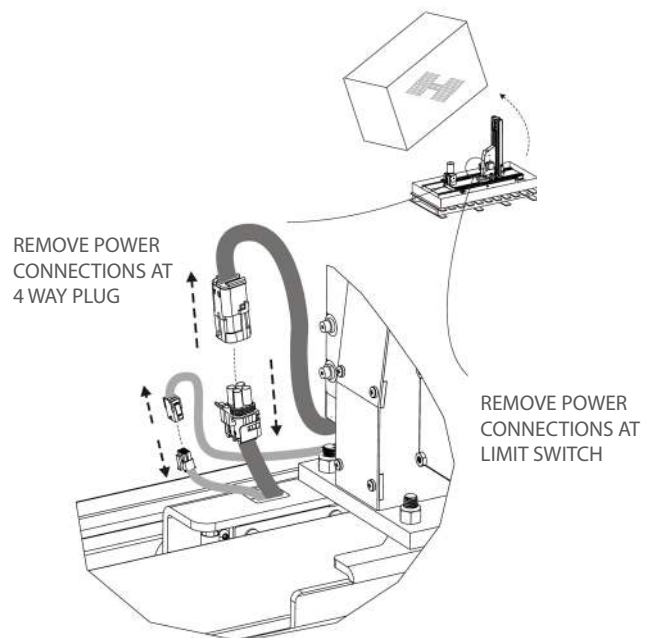

Figure 3-2

2. Remove 4 nuts at tower base. **See Figure 3-3**

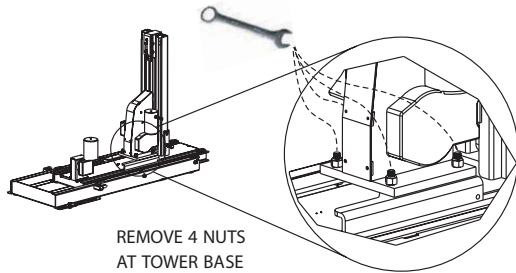

Figure 3-3

3. Lift tower straight up to remove from base. **See Figure 3-4**

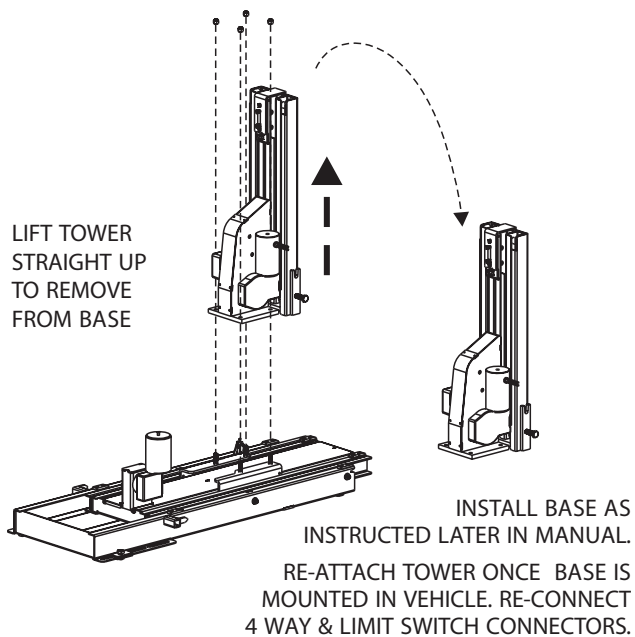

Figure 3-4

4. Install base as instructed later in manual.
5. Re-attach tower once the base is mounted in the vehicle. Re-connect 4-way and limit switches connectors.

SECTION 4 INSTALLATION

WIRING THE VEHICLE

Improper wiring is the main cause of problems in the operation of a vehicle lift. Follow the wiring instructions carefully.

The vehicle wiring harness is located in the hardware pack. The harness is manufactured to comply with SAE J1128 requirements. It is approximately 19 feet long and will accommodate most vehicles.

1. Unwind the wiring harness and lay it flat. One end of the harness has two (2) covered pins. This is the lift end and goes to the rear cargo area where the lift will mount.

The wiring harness is unassembled for easier installation. The end connector is included separately from the harness to enable running the wire under and through the vehicle with the smallest clearance possible.

2. Route the wire harness beginning at the battery. Attach the black wire to the negative terminal on the battery. Do NOT connect the red wire to the battery until the very end. **See Figure 4-1.**

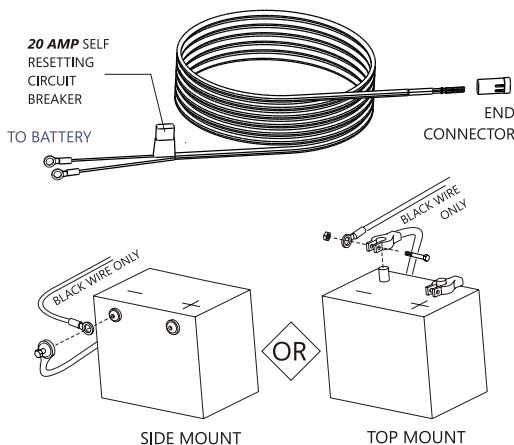

Figure 4-1

3. Run the vehicle harness under and, when possible, through the vehicle back to the rear cargo area/trunk, gaining entry into the vehicle through the firewall. If you want to run the harness under the vehicle, you will most likely need to drill a hole to get the wire into the rear cargo area/trunk. Use the supplied $\frac{3}{8}$ grommet in the hole to protect the wire. **See Figure 4-2.**

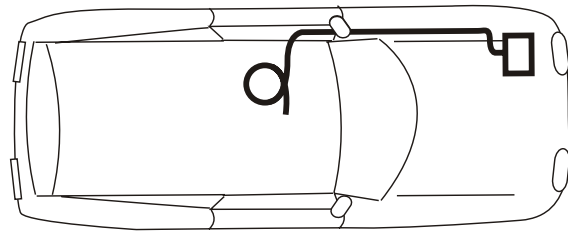

Figure 4-2

⚠ CAUTION

Never attempt to connect the harness to a secondary power source. Always connect both leads directly to the battery.

If the installation requires the wiring harness to run on the underside of the vehicle, route it away from the exhaust system, brake lines, fuel lines, gas tank and any moving parts. Avoid pinch points and sharp edges. Avoid locating the harness where it can be snagged by road debris.

If the harness is too long for the vehicle, coil the excess wire and secure it to the vehicle frame with the supplied tie wraps. Do NOT cut or shorten the harness.

- When harness is through the vehicle, remove the pin's protective tubing. *See Figure 4-3.*

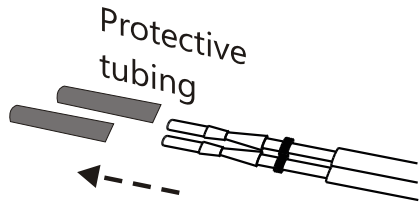

Figure 4-3

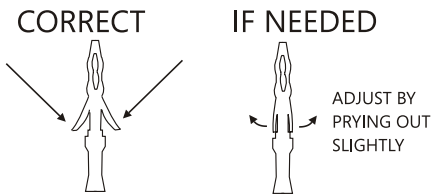

Figure 4-4

- Flip open end connector's hinged retainer.
 - Insert pins as shown. *See Figure 4-5*
 - Verify the wires cannot be pulled out by moderately pulling on the wires. Be sure rubber seals are inside the back of the connector.
 - Close the hinged retainer.
 - Plug connector into lift.

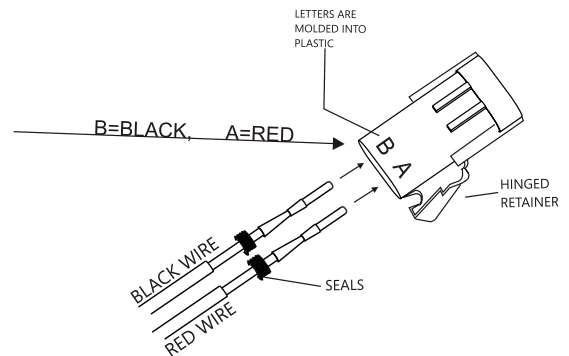

Figure 4-5

- Last, attach red wire to the positive terminal on the battery. *See Figure 4-6.*

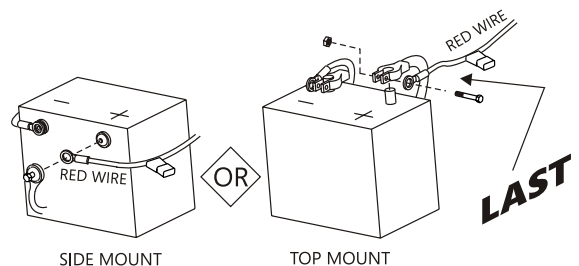

Figure 4-6

NOTICE

Troubleshooting with a test light or voltage meter may give a false indication.

When you probe for 12-volts, the reading may indicate a connection, even if the connection is not necessarily sufficient. The lift's motor can draw up to 20 Amps at some points, requiring all of the available wire to flow proper current. Poor connections are the #1 problem associated with a slow, intermittent, warm, poorly performing motor, which will also deteriorate prematurely.

If a single strand of a multi-strand wire is making contact, 12V will appear on a meter or test light, but it will not allow the motor to operate.

It is always best to test both current and voltage, or run the motor with a known good shop battery or power source when troubleshooting.

AUTOMOTIVE TEST LIGHT

VOLTAGE METER

- Inspect the pin's retaining flanges. The flanges may have been deformed while being run through the vehicle. These are critical to secure the pins inside the connector. Adjust as needed. *See Figure 4-4.*

AL600 INSTALLATION WITH REMOVABLE 3RD ROW SEATING

1. Remove 3rd Row Seating. *See Figure 4-7.*

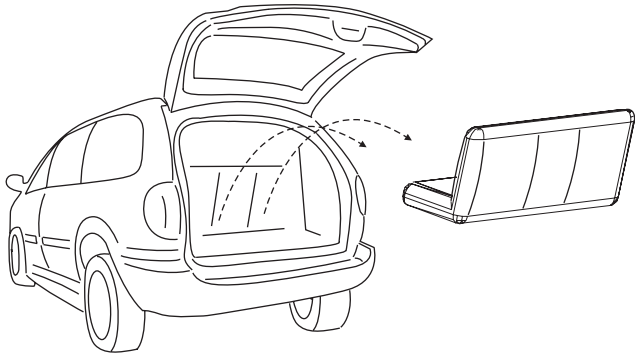

Figure 4-7

2. The AL600 Leg must be mounted between 32" and 42" from the internal surface of the closed back door of the vehicle. *See Figure 4-8.*

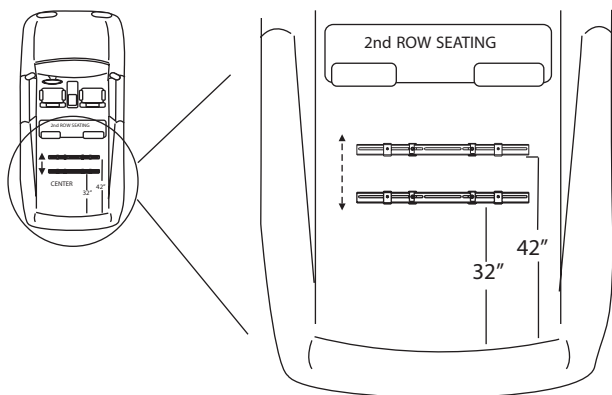

Figure 4-8

3. Examine the Floor for Additional Seat Attachment Points. These must be recessed into the floor. *See Figure 4-9.*

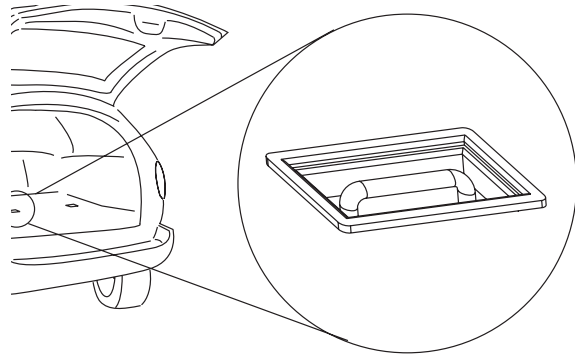

Figure 4-9

4. If Seat Attachment Points ARE Available: *See Figure 4-10 for mounting diagram.*

If Seat Attachment Points are NOT Available:
Look under vehicle in approximate area where Leg will need to be mounted.

See Figure 4-11 for mounting diagram.

Drill a pilot hole first, up from under the vehicle to ensure nothing will be damaged.

Find hole from inside vehicle and drill $\frac{3}{8}$ " hole down through vehicle's floor.

CAUTION

Avoid Gas Tank, Fuel / Brake / Electrical Lines

NOTICE

Attachment Points **MUST** be FLUSH or LOWER than the floor.

INSTALLATION

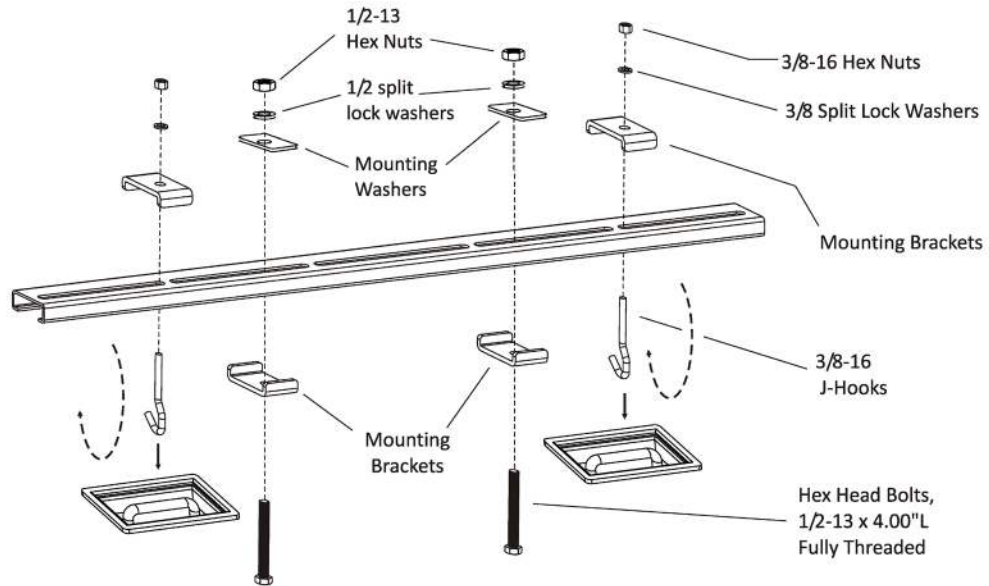

Figure 4-10

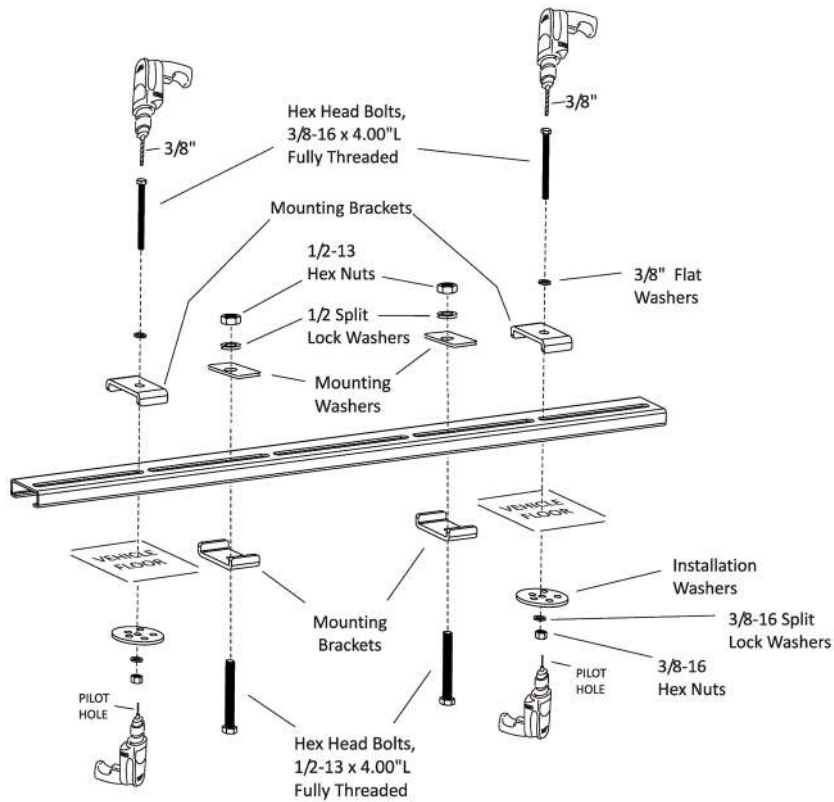
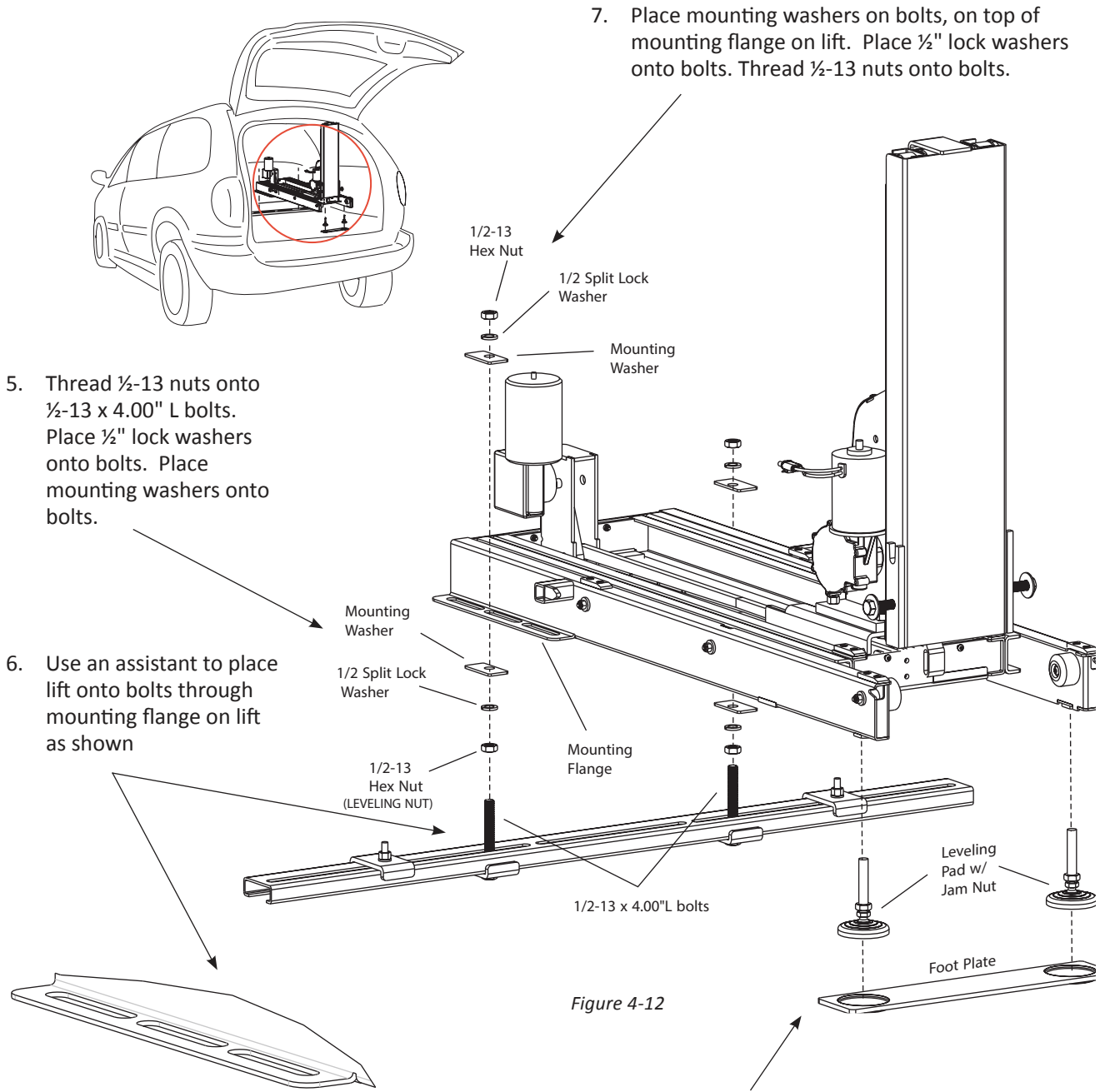

Figure 4-11

INSTALLATION



5. Thread 1/2-13 nuts onto 1/2-13 x 4.00" L bolts. Place 1/2" lock washers onto bolts. Place mounting washers onto bolts.
6. Use an assistant to place lift onto bolts through mounting flange on lift as shown
7. Place mounting washers on bolts, on top of mounting flange on lift. Place 1/2" lock washers onto bolts. Thread 1/2-13 nuts onto bolts.

Figure 4-12

8. Lift front end of lift and install leveling pads as shown. Place foot plate under leveling pads. Lower lift and check with a level. Adjust by threading nut on leveling pads and threading bottom nut under mounting flange.

⚠ WARNING

If no assistant is available, follow instructions on page 14 to avoid injury.



9. Plug hand controller into lift. **See Figure 4-13.**

Connect to vehicle harness. **See Figure 4-14.**



Figure 4-13

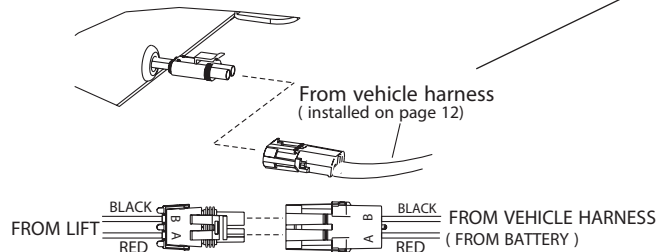

Figure 4-14

10. Press the power button and run the lift out to attach the platform. The Power button must be pressed to enable the hand control to operate. At which time, buttons will light up and front LEDs will act as a flashlight. If no button is pressed after approx. 2-minutes, the hand control will turn off automatically. To turn the hand control back on, the power button will have to be pressed again. With the lift in the out position, hook the platform onto the side flanges of the lifts tower. **See Figure 4-15.**

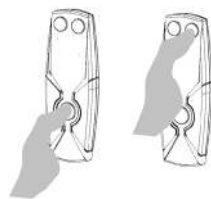
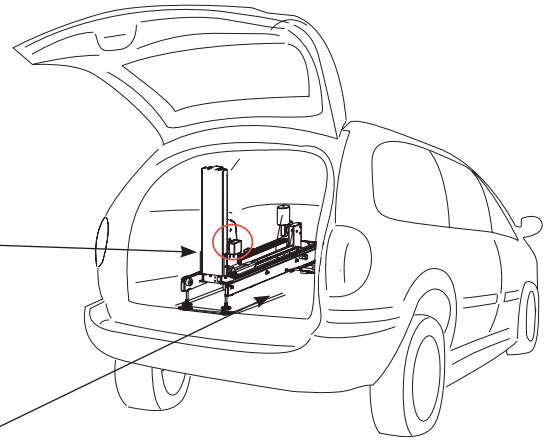

Figure 4-15



11. Attach platform by placing platform's upright pins into u-shaped bracket on tower. **See Figure 4-16.**

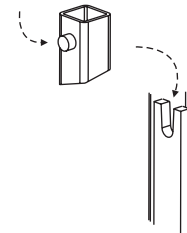

Figure 4-16

12. Thread ½-13 x 1-¾" L Hex head Bolts and ½" washers into threaded holes as shown. Test full motion of lift into and out of the vehicle. Be sure lift is level and no obstructions interfere with platform travel. **See Figure 4-17.**

Tighten all fasteners from all steps at this time.

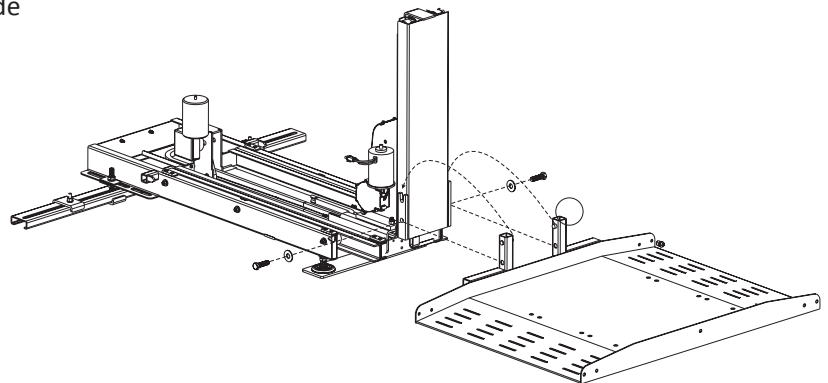

Figure 4-17

HYBRID VEHICLE LIFTS: SECTION 4 INSTALLATION

WITH FOLDING 3RD ROW SEATING

NOTE: A BA-02 Kit is needed for this installation. More detailed instructions on BA-02 installation will be provided with the BA-02 Kit. **See Figure 4-18.**

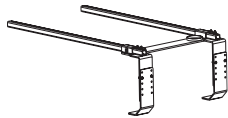

Figure 4-18

1. Fold 3rd Row seating up, exposing the storage well. **See Figure 4-19.**

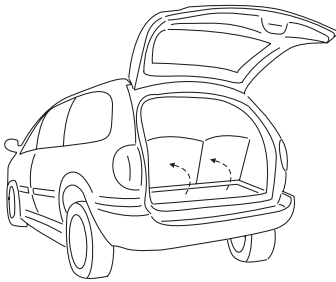

Figure 4-19

2. Measure the height of the well. **See Figure 4-20.**

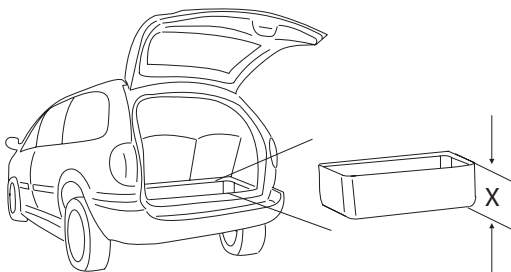

Figure 4-20

3. Position brackets as shown. Slide up or down until you achieve the measured well height. (Holes are arranged for 1/4" increments) **See Figure 4-21.**

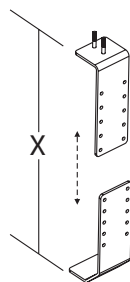

Figure 4-21

4. Attach brackets together and fasten using supplied hardware. **See Figure 4-22.**

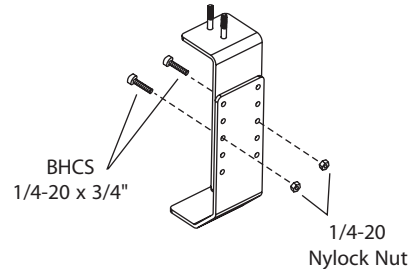

Figure 4-22

5. Position assembled parts around third row seat(s) then fold into well. **See Figure 4-23.**

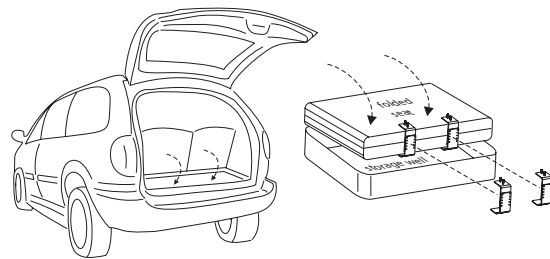

Figure 4-23

6. Install set screws (leave loose) as shown. Slide foot plate assembly onto legs. **See Figure 4-24.**

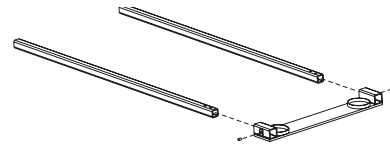

Figure 4-24

7. Attach rails to brackets. **See Figure 4-25.**

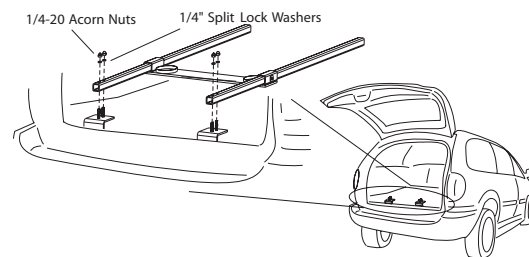

Figure 4-25

8. With BA-02 installed in rear cargo area, examine floor for area to install leg assembly.
See Figure 4-26.

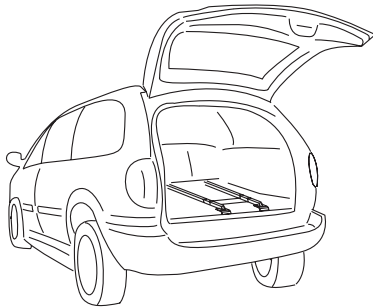

Figure 4-26

9. The AL600's leg will need to be mounted between 32" and 42" from the internal surface of the closed back door of the vehicle.
 Examine the floor for additional seat attachment points recessed into the floor.
See Figure 4-27.

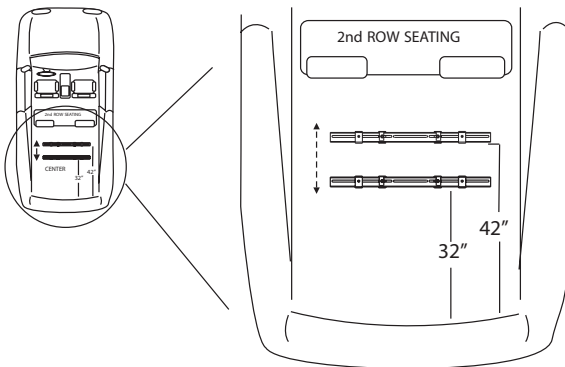

Figure 4-27

⚠ CAUTION

Avoid Gas Tank, Fuel / Brake / Electrical Lines

NOTICE

Attachment Points MUST be FLUSH or LOWER than the floor.

10. If Seat Attachment Points ARE Available:
See Figure 4-28 for mounting diagram.

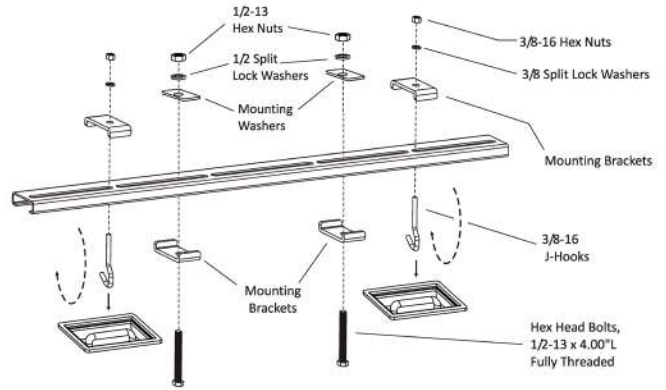

Figure 4-28

If Seat Attachment Points are NOT Available:
 Look under vehicle in approximate area where Leg will need to be mounted.

Drill a pilot hole first, up from under the vehicle to ensure nothing will be damaged.
See Figure 4-28.

Find hole from inside vehicle and drill 3/8" hole down through vehicle's floor. **See Figure 4-29.**

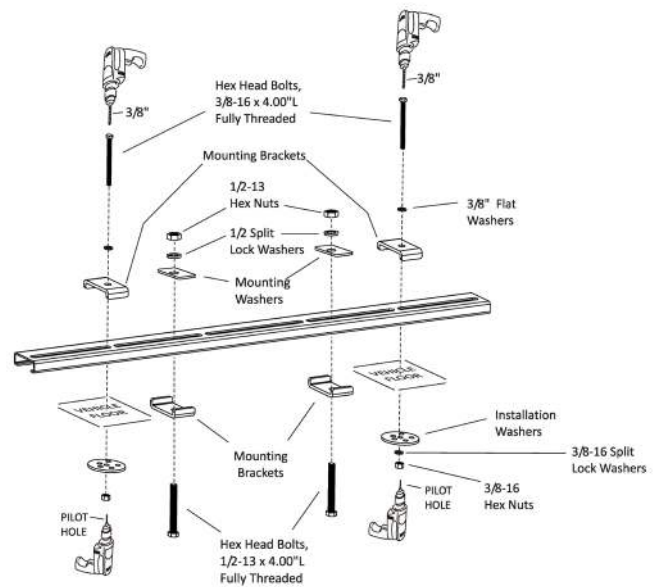
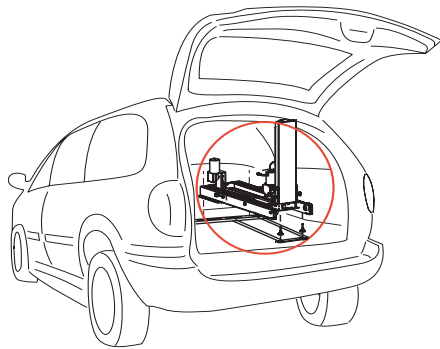

Figure 4-29

INSTALLATION



11. Thread ½-13 nuts onto ½-13 x 4.00" L bolts. Place ½" lock washers onto bolts. Place mounting washers onto bolts.

13. Place mounting washers on bolts, on top of mounting flange on lift. Place ½" lock washers onto bolts. Thread ½-13 nuts onto bolts.

12. Use an assistant to place lift onto bolts through mounting flange on lift as shown.

14. Lift front end of lift and install leveling pads as shown. Place pads into circular cups of BA-02 as shown. Lower lift and check with a level. Adjust by threading nuts on leveling pads and threading bottom nut under mounting flange.

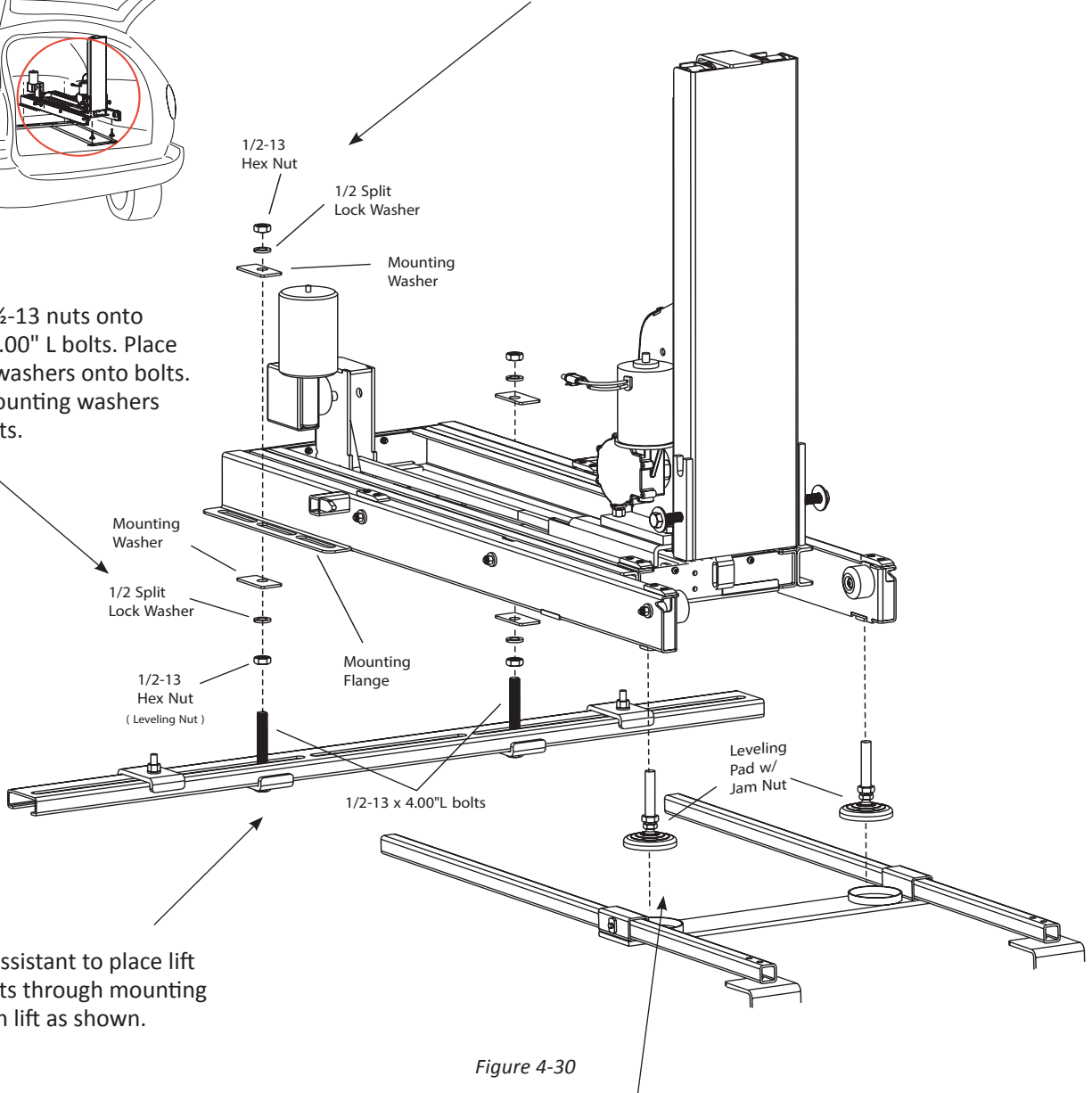

Figure 4-30

⚠ WARNING

If no assistant is available, follow instructions on page 14 to avoid injury.

15. Plug hand controller into lift. *See Figure 4-31.*

Connect to vehicle harness. *See Figure 4-32.*



Figure 4-31

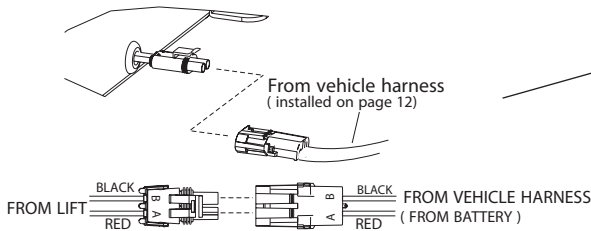

Figure 4-32

16. Press the DOWN button until the lift's tower has moved out of the vehicle. *See Figure 4-33.*

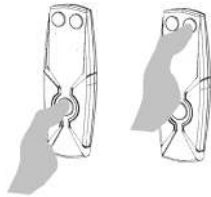
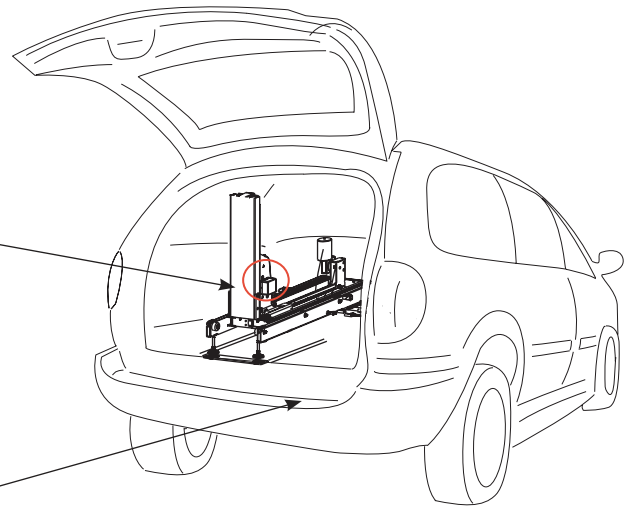

Figure 4-33



17. Attach platform by placing platform's upright pins into u-shaped bracket on tower. *See Figure 4-34.*

See Figure 4-34.

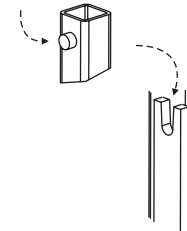

Figure 4-34

18. Thread $\frac{1}{2}$ -13 x 1- $\frac{3}{4}$ " L Hex head Bolts and $\frac{1}{2}$ " washers into threaded holes as shown. Test full motion of lift into and out of the vehicle. Be sure lift is level and no obstructions interfere with platform travel. *See Figure 4-35*

Tighten all fasteners from ALL steps at this time.

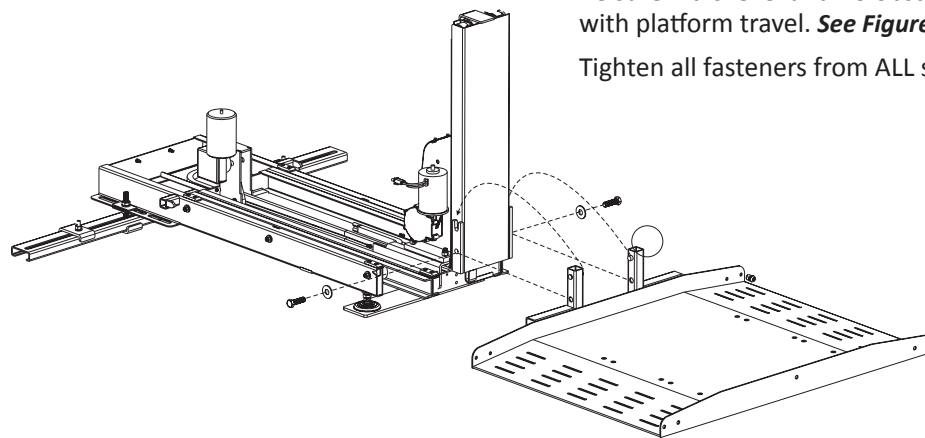

Figure 4-35

AL690 INSTALLATION

INSTALLING THE FRONT LEG

1. Remove 2nd Row Seating. *See Figure 4-36.*

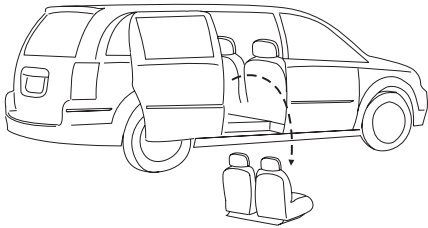

Figure 4-36

2. The AL690's front leg must be mounted between 42" and 52" from the internal surface of the closed side door of the vehicle.



Figure 4-37

3. Examine floor area for remaining seat attachment points that are recessed into the floor. *See Figure 4-38.*

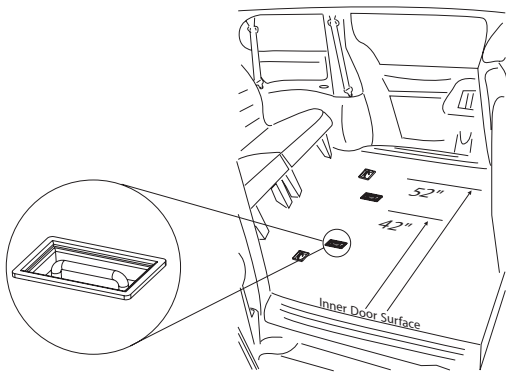

Figure 4-38

4. If Seat Attachment Points ARE Available: *See Figure 4-39 for mounting diagram.*

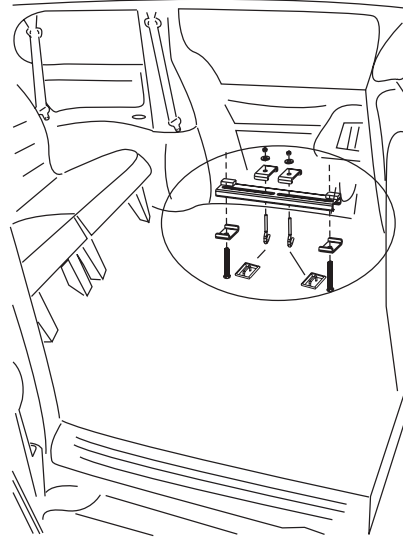

Figure 4-39

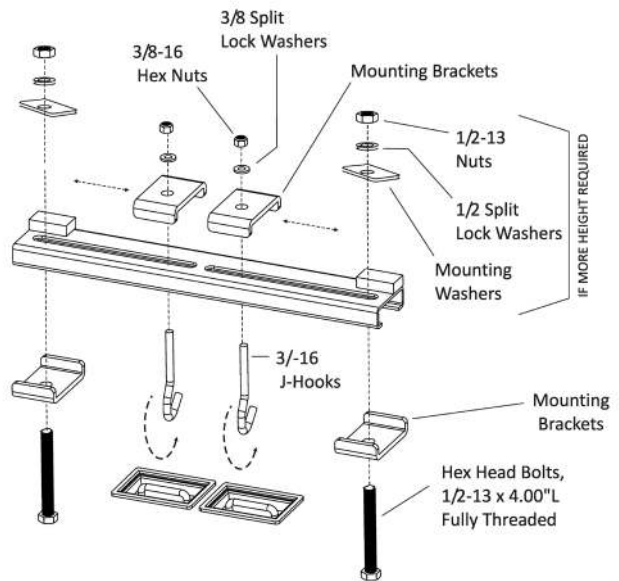

Figure 4-40

NOTICE

Attachment Points **MUST** be **FLUSH** or **LOWER** than the floor.

If Seat Attachment Points are NOT Available:
 Look under vehicle in approximate area where
 Leg will need to be mounted. **See Figure 4-41**

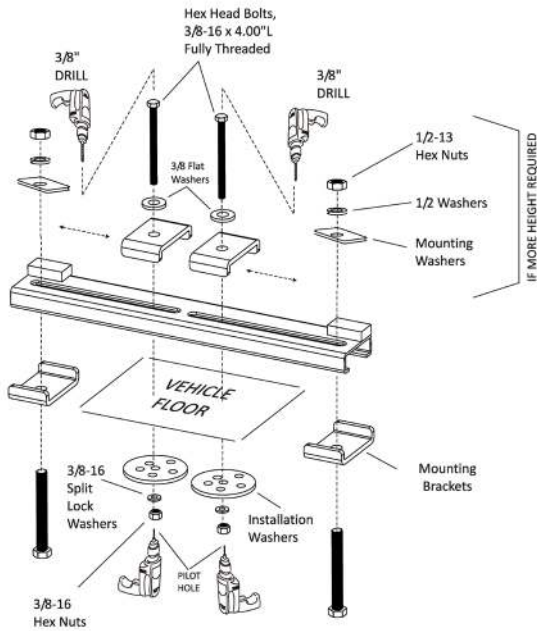

Figure 4-41

Look under vehicle in approximate area where
 leg will need to be mounted.

Drill a pilot hole first, up from under the vehicle
 to ensure nothing will be damaged.

Find hole from inside vehicle and drill 3/8 inch hole
 down through vehicle's floor.

CAUTION

Avoid Gas Tank, Fuel / Brake / Electrical Lines

*Note: False floor support available when applicable for
 vehicles with Stow & Go seating. (2nd row seats must be
 removed) See Figure 4-42*

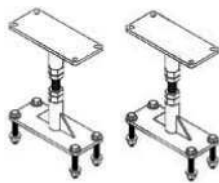

Figure 4-42

INSTALLING THE REAR LEG

1. The AL690's rear leg will be installed
 approximately 24" to 36" from the front leg.
See Figure 4-43.

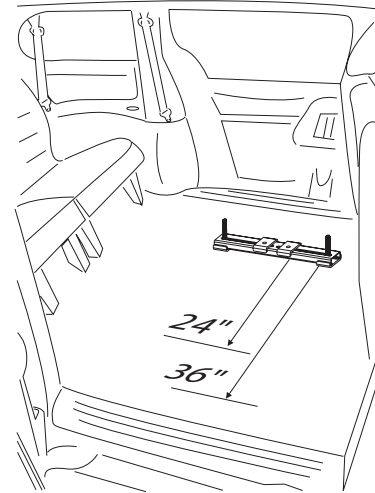

Figure 4-43

2. The uprights on both legs must be in line and
 square. Verify by measuring corner to corner.
 Distance should be identical. **See Figure 4-44.**

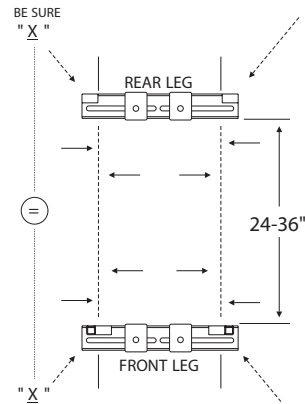
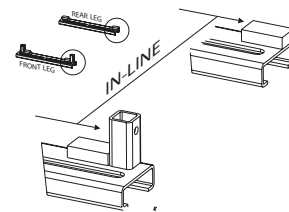

Figure 4-44

HYBRID VEHICLE LIFTS: SECTION 4 INSTALLATION

3. If Seat Attachment Points ARE Available:
See Figure 4-45 for mounting diagram.

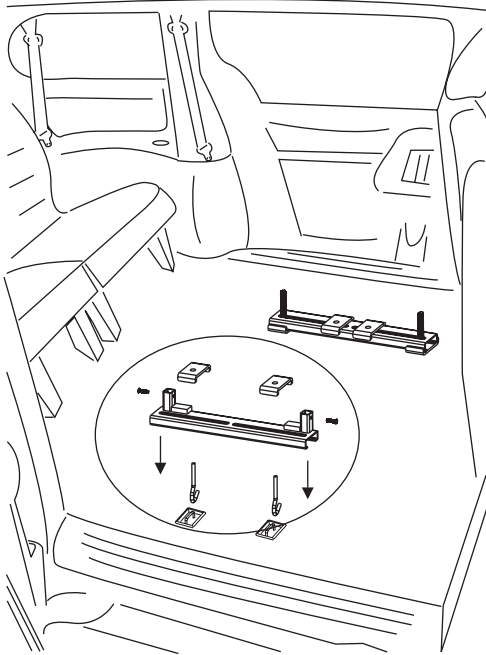

Figure 4-45

- If Seat Attachment Points are NOT Available:
Look under vehicle in approximate area where leg will need to be mounted. **See Figure 4-47.**

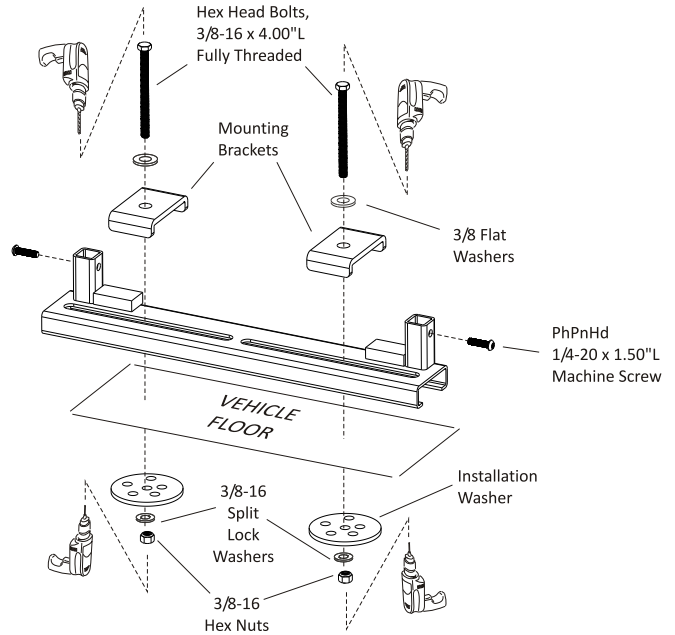

Figure 4-47

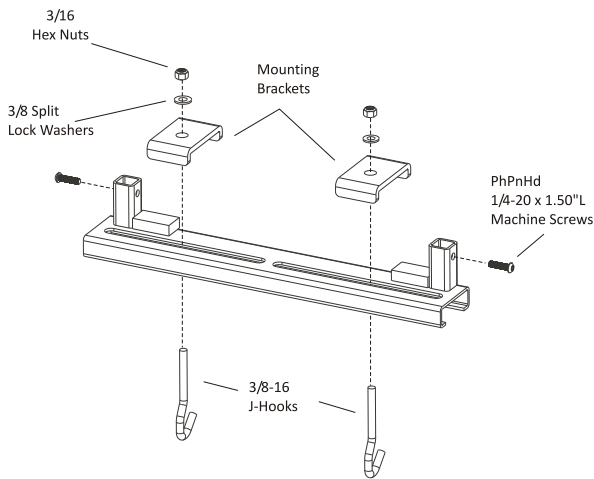

Figure 4-46

Drill a pilot hole first, up from under the vehicle to ensure nothing will be damaged.

Find hole from inside vehicle and drill $\frac{3}{8}$ " hole down through vehicle's floor.

CAUTION

Avoid Gas Tank, Fuel / Brake / Electrical Lines

4. Thread 1/2-13 nuts onto 1/2-13 4.00"L bolts installed previously.

Place 1/2" lock washer onto bolts.

Place mounting washers onto bolts

Using an assistant, place lift onto bolts through mounting flange on lift as shown.

See Figure 4-48.

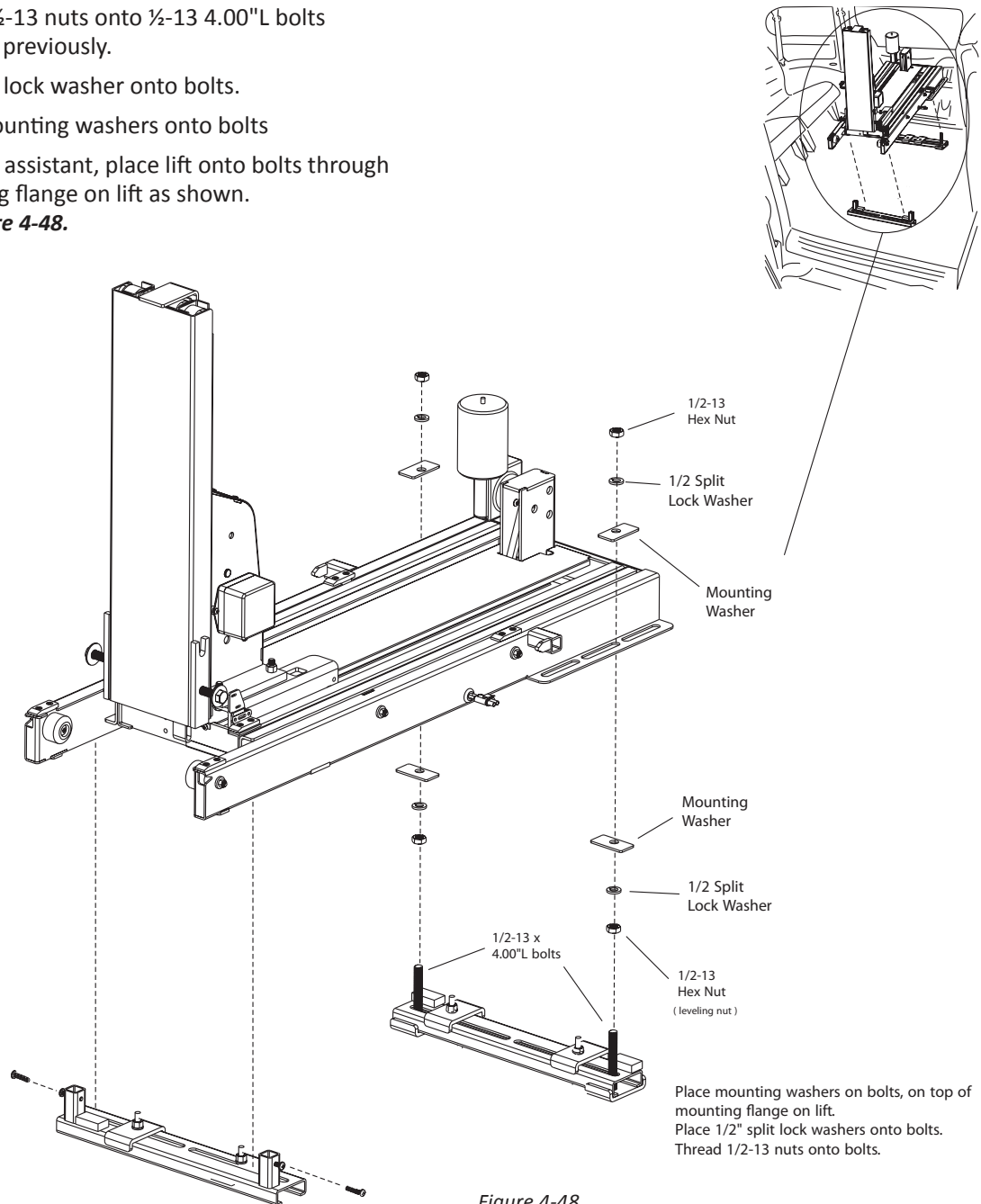

Figure 4-48

⚠ WARNING

If no assistant is available, follow instructions on page 11 to avoid injury.

HYBRID VEHICLE LIFTS: SECTION 4 INSTALLATION

5. Plug Hand Controller into lift. **See Figure 4-49.**



Figure 4-49

6. Connect to vehicle harness. **See Figure 4-50.**

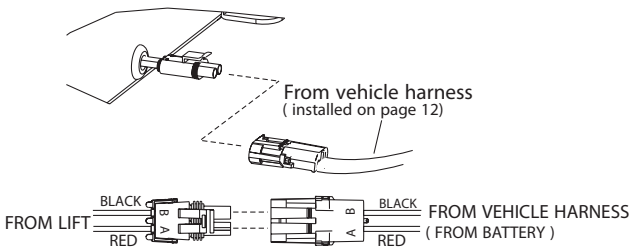

Figure 4-50

7. Press the DOWN button until the lift's tower has moved out of the vehicle. **See Figure 4-51.**

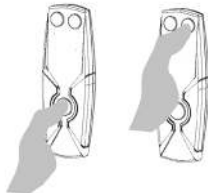

Figure 4-51

The platform components may be re-assembled to match the opening of the vehicle's side door. **See Figure 4-52.**

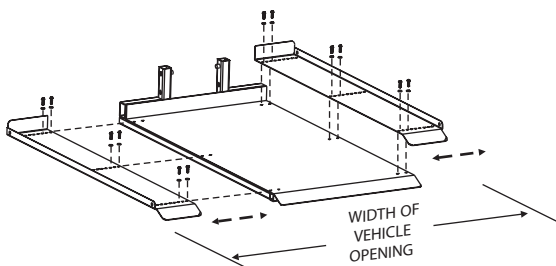
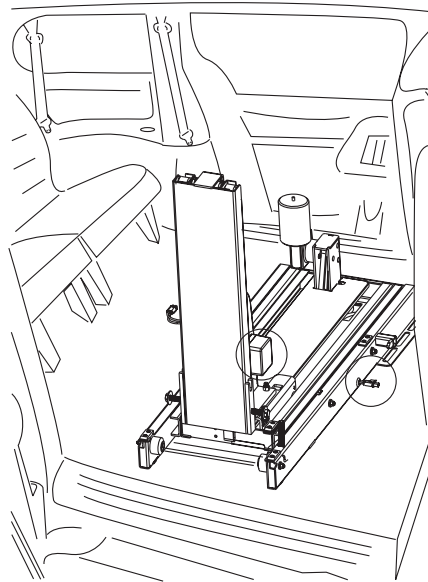

Figure 4-52



8. Attach platform by placing platform's upright pins into u-shaped bracket on tower. **See Figure 4-53.**

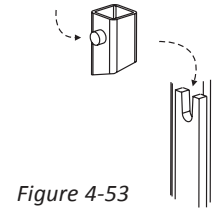

Figure 4-53

9. Install 1/2-13 x 1-3/4" Hex head Bolts and 1/2" flat washers into threaded holes as shown. Test full motion of lift into and out of the vehicle. Be sure lift is level and that no obstructions interfere with the travel of the platform. **See Figure 4-54.**

Tighten ALL fasteners from ALL steps.

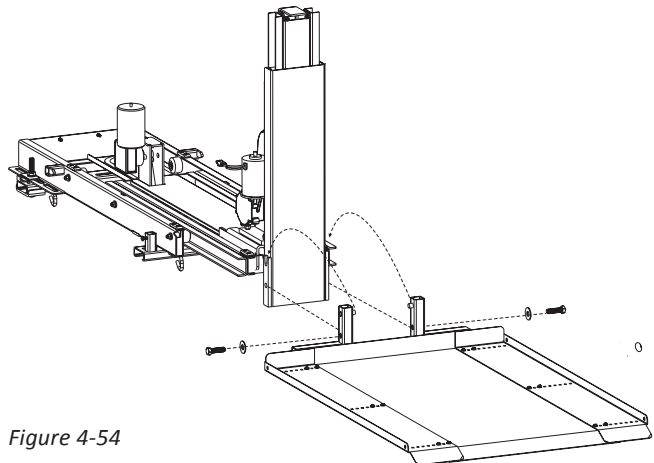

Figure 4-54

CHAIR/SCOOTER PREPARATION

The strap hooks included with your chair can be attached by means of an Anchor Plate (for chairs or scooters with a center seat post) or Anchor U-Bolts (for those without a center post.)

ANCHOR PLATE INSTALLATION

Use Anchor Plate for chairs or scooters with a center seat post.

The Anchor Plate is a flat plate with a slot in each end. This plate attaches to the bottom of the seat and works with any chair or scooter that has a center seat post.

See Figure 4-55.

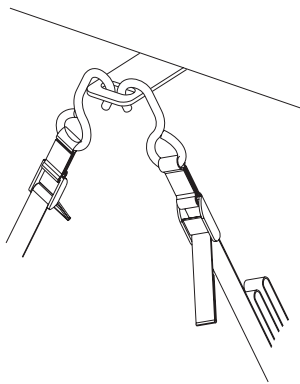

Figure 4-55

1. Remove the chair seat.
2. Loosen the screws that attach the plate to the seat. Allow enough room to slide the anchor plate between the seat and the seat plate. **See Figure 4-56.**

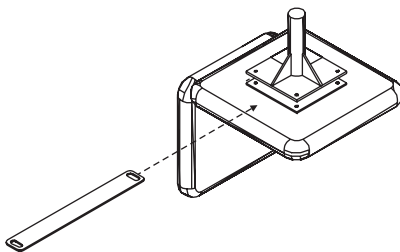

Figure 4-56

3. Make sure the anchor plate will extend about 1-½" on each side of the cushion. This provides space for the user to secure the strap hooks to the chair.
4. Attach the Anchor Plate in the center of the seat plate evenly, with the holes on each end. **See Figure 4-57.**

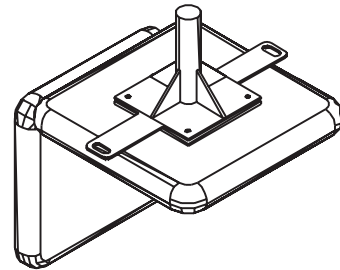

Figure 4-57

5. Re-tighten the screws that hold the seat plate to the bottom of the seat.
6. Replace the seat on the chair. **See Figure 4-58.**

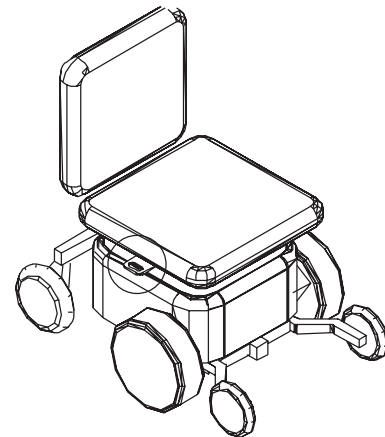

Figure 4-58

ANCHOR U-BOLTS

Use U-Bolts with Power Chairs or Scooter that do not have a center seat post.

1. For power chairs or scooters without a center seat post, the seat is normally attached to a tubular frame. Install the U-bolts, two on each side, to the frame as shown. **See Figure 4-59.**

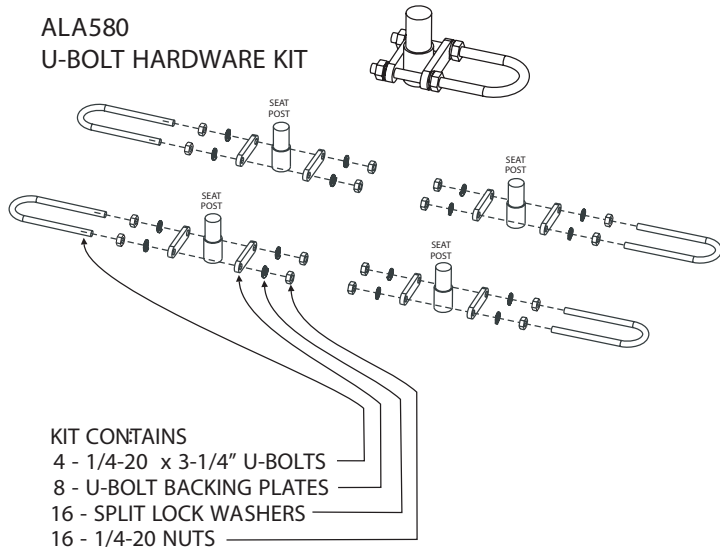

Figure 4-59

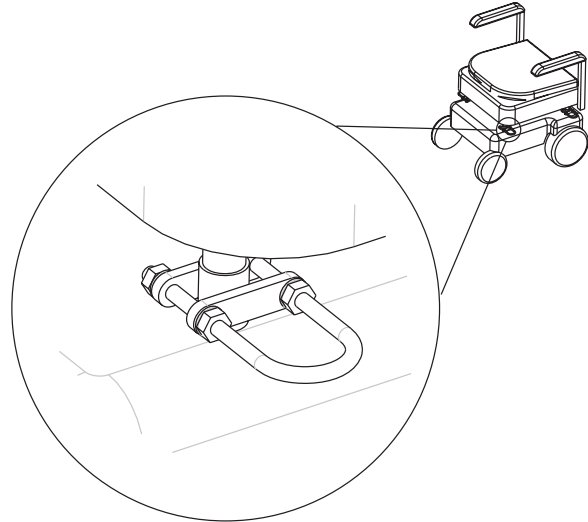

Figure 4-60

2. Ensure that the loop extends to the outside of the chair so the user can attach the strap hooks. **See Figure 4-60.**
3. U-bolt placement will differ among models and manufacturers. Place the U-bolts towards the center of the seat if possible. Due to different seat types, you may be forced to install the U-bolts more towards the front or rear of the seat, but we recommend attaching as close as possible to the center of the seat.

SECTION 5
TROUBLESHOOTING

PROBLEM
Lift does not operate or lift operates slowly or intermittently.
CAUSE
Bad electrical connection(s)/Circuit breaker.
SOLUTION

Check and clean all connections that might be loose or dirty. This is the number 1 cause of a poorly performing lift. The lifting motor requires quality electrical connections to operate at full capacity, any break in the wiring will slow down the motor and it will deteriorate prematurely.

Inspect the full length of the wire harness to ensure the insulation is not torn. The lift's vehicle power harness running through or under the vehicle is subject to road debris and rubbing against the vehicle's frame which can cause a short.

Verify the circuit breaker. The circuit breaker is located about 6" from the connections to the vehicle's battery. The breaker will self-reset if overloaded; however, verify (with Ohm meter or test light) that the breaker is functioning. Or replace it with a new/known good circuit breaker and perform the following tests.

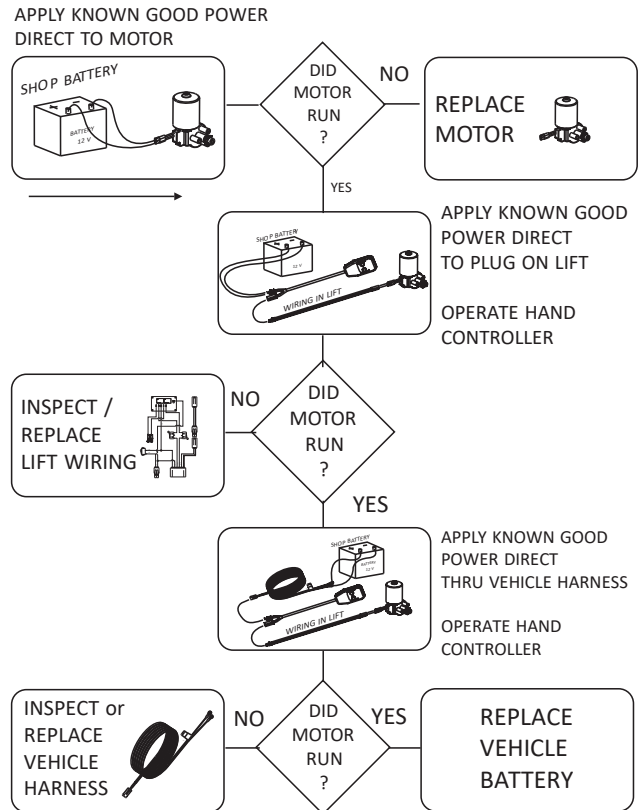
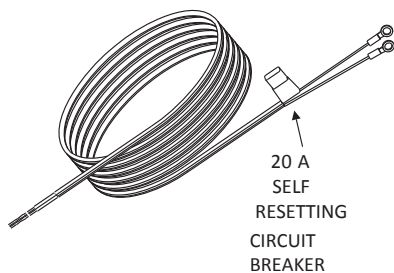

PROBLEM
Scooter/ chair tips to the front or back while being lifted.
CAUSE
Platform is leaning to one side more than the other.
SOLUTION

Adjust the position of the mobility device on the platform. In some cases, a scooter cradle can be added to the platform to allow more offset.

HYBRID VEHICLE LIFTS: SECTION 5

TROUBLESHOOTING

PROBLEM

Lift rattles while driving

CAUSE

Platform is not docked.

SOLUTION

Be sure to press the "IN" button until the platform is fully engaged in its locking mechanism.

MANUAL OVERRIDE

In the event of power failure (for example, if your car battery dies), you can still operate the lift using the manual override system. The AL600 has two motors; the Lifting Motor and the Rotation Motor. The manual override system on both motors is a 1/4" hex located at the center of the armature cover. See Figure 6.1.

See Figure 6.1.

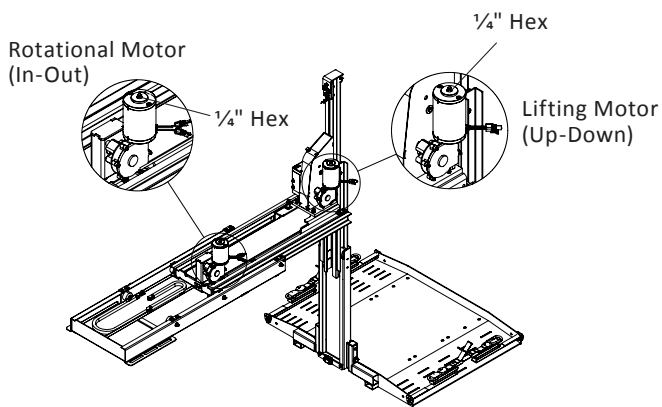

Figure 6-1

⚠️ WARNING

Always disconnect the power from the lift by disconnecting the two connector plugs before attempting to use the manual override to avoid electric shock or unexpected activation of the motor.

Disconnect power from the lift. See Figure 6-2.

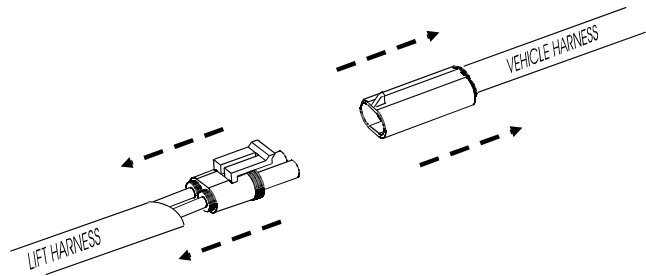

Figure 6-2

Use a 1/4" socket and rotate the hex either Clockwise (CW) or Counter Clockwise (CCW). See Figure 6-3. For Lifting Motor, see Figure 6-4. For Rotational Motor, see Figure 6-5.

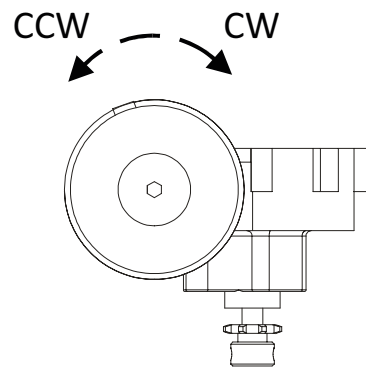

Figure 6-3

⚠️ CAUTION

If using a power drill, start and end with a slow speed. If at anytime the manual override binds or locks up, release the trigger on the drill and stop.
****DO NOT USE IMPACT OR HAMMER DRILL****

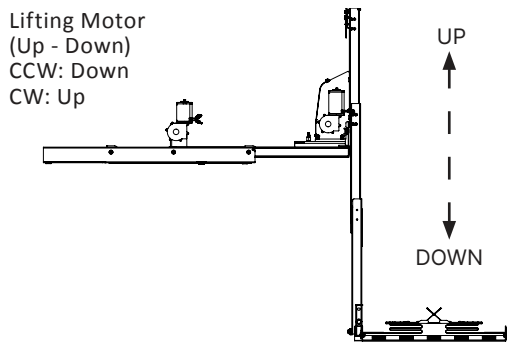

Figure 6-4

CAUTION

Before retracting the lift into the vehicle, be sure that the lift is fully compressed in the UP position. Not doing so may result in damage to the vehicle and/or lift. See Figure 6-4.

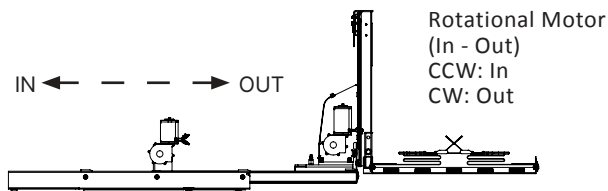

Figure 6-5

SECTION 6

MAINTENANCE & INSPECTION

Annual inspections are highly recommended to help prevent unsafe conditions and operation.

DEALER MAINTENANCE SCHEDULE RECOMMENDED EVERY 6-MONTHS

- Observe lift with and without weight.
- Check wiring travel.
- Inspect chains, clean and lubricate as needed.
- Inspect lifting strap, lifting spool, and flange bearings.
- Clean and lubricate rails with Jet Lube CB-2 Multipurpose Grease, or similar equivalent. **See Preferred Cleaning and Lubrication instructions.**
- Possibly provide weight vs. expected current graph, if field techs have that capability.
- Check for any powder coat chips or scratches and touch up with black enamel or similar paint as necessary.
- Grease platform roller bearings.
- Check for any loose fasteners. **See torque specs on page 6.**
- If applicable, test the function of the retractor straps.

RECOMMENDED ANNUALLY

- Replace batteries (if equipped)

PREFERRED CLEANING AND LUBRICATION MAINTENANCE

Should the lift become sluggish, cleaning and lubrication are required. Clean the rails thoroughly using shop rags, a degreaser, or denatured alcohol. Once the old grease and dirt are removed, wipe rails one more time with denatured alcohol and a microfiber towel to assure not only a clean surface but a surface on which the new grease will adhere.

It is a good idea to coat the entire rail surface with grease.

NOTE: There is no particular order to the application of the grease. There is no requirement to remove the lift from the vehicle to perform this maintenance.



1500 Independence Blvd., Suite 220
Sarasota, FL 34234
800-833-0478
www.harmar.com